

NOTES

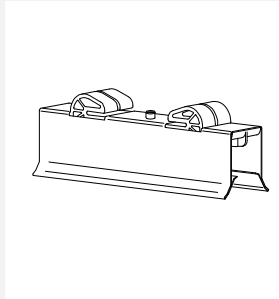

MATERIALS

0.7 mm mill finish aluminum
Polyamide

SUITABLE FOR

Riverclack 500
Riverclack 550

INCLUDED COMPONENTS

- N°1 bent aluminum profile
- N°1 polyamide bracket with fixing hooks
- N°1 PV panel stopper
TCEI 5.5 x 16 stainless steel self-tapping screw, head D = 10 mm
- N°1 310 ml cartridge of silicone (for n°10 Climpos)

RELATED COMPONENTS

- Header Climpo RSA 303
- Dedicated iron fastener

NOTES

- For aluminum roofs
- Not applicable on profiles produced before 2001
- Fixing system suitable for PV panels with aluminum frame, indicative dimensions: 1.65 x 1 metres
- It is recommended to employ one Climpo every sheet rib
- The system requires a transversal positioning of the modules in relation to the length of the sheet
- Verify the suitability of the system according to the specifications provided by the module manufacturer
- Perform a compatibility check of the module frame and the Climpo system; compatibility does not fall under ISCOM's responsibility

WWW.RIVERCLACK.COM

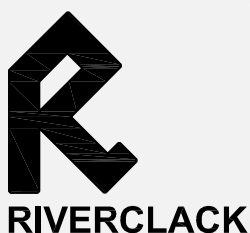

TECHNICAL SITUATION

EXPLODED VIEW

PV PANEL STOPPER SCREW, HEAD D=10 mm



ADDITIONAL SPACER



ALUMINUM PROFILE

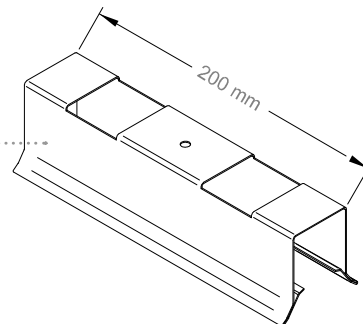

POLYAMIDE BRACKET WITH FIXING HOOKS

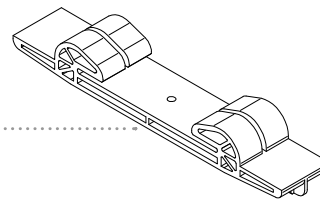

SECTION

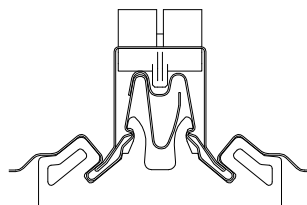

ADMISSIBLE LOADS

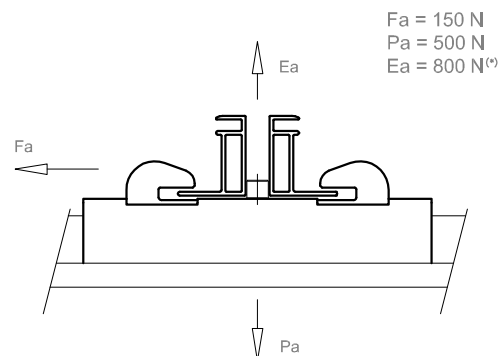

(*) - for Riverclack sheets produced after 2005
- before 2005 consider $E_a = 600 \text{ N}$

The design by a competent technician is always recommended, pay special attention to loads deriving from extreme weather conditions

NOTES

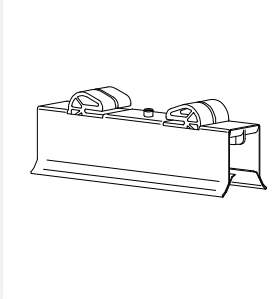

NOTES

- Slope of the roof must be lower than 10%, higher slopes require additional fasteners (contact ISCOM)
- Do not consider Climpo PV assembly as a snow guard. Snow loads must be handled with proper devices
- Using the stopper screw there is a distance of 10 mm between PV modules (screw head diameter)
- Admissible dimensions of PV module frame are shown in Tab.1; with different frames (Tab.2) request the proper spacer
- Start and end the laying of the PV field using the Short Header Climpo RSA 303 for better architectural integration
- To make the fixing on Riverclack sheet ribs easier, the use of the proper iron fastener is recommended; request it at time of order
- For assembly follow specific ISCOM instructions
- It is possible to install the item on curved panels with radius >30 m. You may install the item even if radius is <30 m and >5 m, but in this case PV panels must be fixed on profiled interface elements, not on Climpo clamps directly
- For different applications, contact ISCOM
- Weight: approx. 150 grams
- Patented, n° 1662727

WWW.RIVERCLACK.COM

TECHNICAL SITUATION

COMPATIBILITY OF THE SYSTEM

unit of measurement (mm)

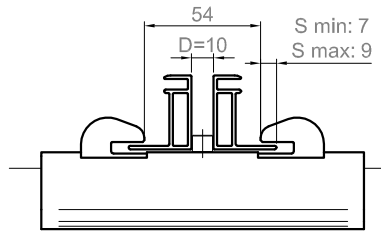
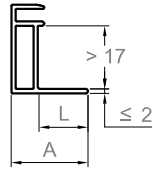

APPLICATION EXAMPLE

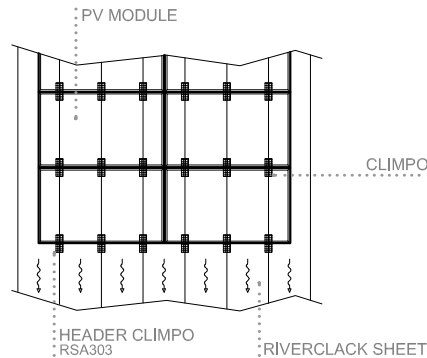

Tab.1

With stopper screw only (D=10)	
A	L
31	≥19
30	≥17
29	≥15

Tab.2

		With spacer addition (D)							
		A							
L	15	26	24	22	20	18	16	14	12
	17	28	26	24	22	20	18	16	14
	≥ 19	30	28	26	24	22	20	18	16

Unit of measurement (mm)

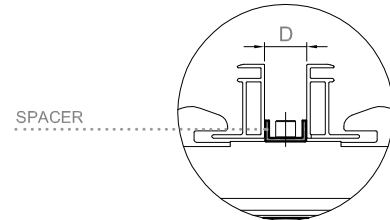

INSTALLATION SEQUENCE

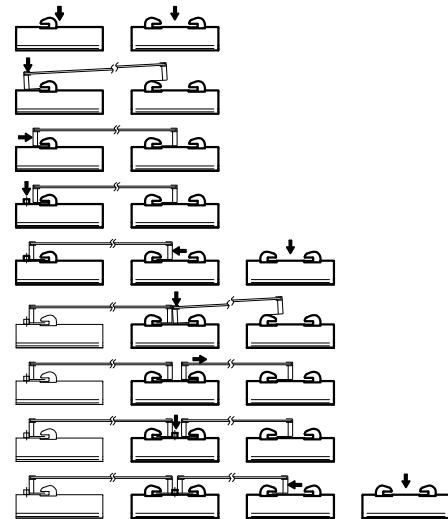

SILICONE

